

## Prostore 800

### 2½ Door Digital Refrigerator, 720lt (0/+10 °C) - R290

ITEM # \_\_\_\_\_

MODEL # \_\_\_\_\_

NAME # \_\_\_\_\_

SIS # \_\_\_\_\_

AIA # \_\_\_\_\_

**691351 (PS09R2FHC)**

 2-½ door prostore  
 Refrigerator 720lt, 0/+10°C,  
 AISI 304, R290

### Short Form Specification

#### Item No.

Two half door refrigerator constructed in 304 AISI stainless steel with external bottom panel in anti-corrosive material. Large digital display featuring humidity selection button (3 preset level), cabinet temperature display and setting and turbo frost cycle (to rapidly cool warm loads). HACCP-compliant control with alarms and history. Frost Watch Control to defrost only when required with automatic evaporation of defrost water. Optimized airflow provides even temperature distribution on all grids. Fitted with 65 mm-thick polyurethane insulating foam. Self-closing, on-site reversible door features microswitch to switch off the fan when the door is opened. Hidden evaporator to guarantee higher storage capacity and less corrosion problems. Built-in refrigeration unit; ventilated operation; Interior LED light. For ambient temperatures up to 43 °C. CFC and HCFC free. R290 highly ecological refrigerant type, cyclopentane gas in foam. Supplied with 5 x 700X530mm Rilsan coated grids and n. 5 sets of 2 stainless steel grid runners. Prearranged to fit RS485 port to facilitate connection to a remote computer and integrated HACCP systems.

### Main Features

- Prearranged for remote alarm.
- Large digital white-digit display with humidity selection button (3 preset level), cabinet temperature display and setting and turbo frost cycle (to rapidly cool warm loads).
- IPX5 frontal water protection.
- Connectivity ready for real time access to connected appliances from remote and data monitoring (requires optional accessory).
- Fully compliant HACCP digital control: when temperature exceeds critical limits, acoustic and visual alarms are activated. Up to two months of event are kept in memory.
- Large storage area suitable to contain 700x530 mm grids to improve net capacity.
- Optimized airflow within the chamber guarantees uniformity of temperature on all grids.
- Hidden evaporator thus guaranteeing higher storage capacity and less corrosion problems.
- Greater storage space: internal structure with numerous charging positions available to host grids, ensuring higher net capacity.
- Adjustable temperature range from 0°C to +10°C.
- Model requires only 1 phase 230V/50Hz supply and can be plugged straight into an existing power socket.
- Prearranged to fit RS485 port to facilitate connection to a remote computer and integrated HACCP systems.
- Complies with main international certification bodies and is CE marked.
- Low noise level.
- Self closing and on site reversible left/right doors.
- This appliance is intended for use in ambient temperatures up to 40°C.

### Construction

- Developed and produced in ISO 9001 and ISO 14001 certified factory.
- Stainless steel AISI 304 external panels (galvanized external back).
- Inner cell with rounded corners, bottom pressed in only one piece.
- Stainless steel runners and supports easily disassembled.
- Internal components removable without the use of tools to facilitate cleaning operations.
- Pressed stainless steel door handle without joints gathering dust and dirt.
- Easy access to the main components for maintenance.

**APPROVAL:** \_\_\_\_\_

- Lockable door.

## Sustainability



- Frost Watch Control: fully automatic defrost starts only when ice is actually building-up in the evaporator and adapt the defrosting duration to guarantee perfect ice removal while optimizing energy efficiency consumption.
- CFC and HCFC free, highly ecological refrigerant type: R290 (ecological gas in foam: cyclopentane). Hydrocarbon refrigerant gas R290 for the lowest environmental impact (GWP=3), to reduce green house and ozone depletion effects.
- Insulation thickness: 65 mm of polyurethane injected with ecological foaming gas cyclopentane to ensure effective insulation with minimum energy consumption (thermal conductivity: 0,020 W/m\*K).
- Removable triple-chamber balloon magnetic gasket to improve insulation and reduce energy consumption and ease of cleaning.
- Cleaning-free condenser: the structure of the wire frame condenser prevents dust and grease accumulation thus avoiding periodical cleaning operations and reducing energy consumption.
- Optical door microswitch to stop the fan once the door is opened, thus minimizing energy waste.
- Interior LED light to save energy and for best internal visibility.
- Automatic evaporation of the defrosting water by hot gas on the top for energy saving.

## Included Accessories

- 4 of Pair of runners for 470 and 720lt PNC 880335 prostore cabinets
- 4 of Plastic-coated grid 700x530mm PNC 880343 for Prostore 720l

## Optional Accessories

- Stainless steel grid 2/1GN for prostore cabinets PNC 880160
- 2/1GN Plastic-coated grid PNC 880306
- Pair of runners for GN 2/1 grids, for prostore cabinets PNC 880320
- Stainless steel grid (700x530) PNC 880323
- Pedal opening for cabinets PNC 880324
- Kit 4 feet, height 200mm PNC 880325
- Kit of 4 feet-h=67 (marine) PNC 880326
- Kit pair of runners (marine) PNC 880327
- Pair of runners for 470 and 720lt prostore cabinets PNC 880335
- Plastic-coated grid 700x530mm for Prostore 720l PNC 880343

Front

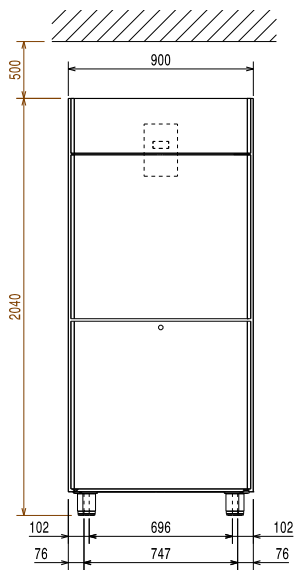

Side

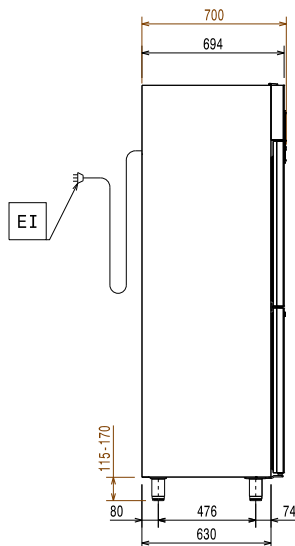

EI = Electrical inlet (power)

Top

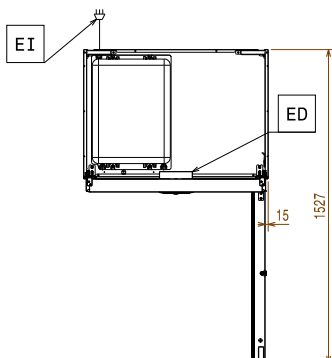

### Electric

Supply voltage:	691351 (PS09R2FHC)	220-240 V/1 ph/50 Hz
Electrical power max.:		0.17 kW

### Key Information:

Gross capacity:	720 lt
Net Volume:	510 lt
Door hinges:	2 Right
External dimensions, Width:	900 mm
External dimensions, Depth:	700 mm
External dimensions, Depth with Doors Open:	1527 mm
External dimensions, Height:	2040 mm
Number and type of doors:	2x1/2 Full
Internal Dimensions, Width:	772 mm
Internal Dimensions, Depth:	582 mm
Internal Dimensions, Height:	1436 mm
Height adjustment:	15/40 mm
Number and type of grids (included):	5 - 530x700
Type of external material:	304 AISI
Type of internal material:	304 AISI
Number of positions & pitch:	44; 22 mm

### Refrigeration Data

Control type:	Digital
Compressor power:	1/4 hp
Refrigeration power at evaporation temperature:	-10 °C
Operating temperature min.:	0 °C
Operating temperature max.:	10 °C
Operating mode:	Ventilated
Cooling unit:	Built-In
Defrost type:	By Air

### Product Information (EU Regulation 2015/1094)

Type of model (EU Reg. 2015/1094):	vertical chilled
------------------------------------	------------------

### ISO Certificates

ISO Standards:	ISO 9001; ISO 14001; ISO 45001; ISO 50001
----------------	---

### Sustainability

Energy Class (EU Reg. 2015/1094):	B
Yearly and daily energy consumption (EU Reg. 2015/1094):	506kWh/year - 1kWh/24h
Climate class (EU Reg. 2015/1094):	Heavy Duty (5)
Energy Efficiency Index-EEI (EU Reg. 2015/1094):	34.96
Refrigerant type:	R290
GWP Index:	3
Refrigeration power:	406 W
Refrigerant weight:	115 g

 Prostore 800  
 2½ Door Digital Refrigerator, 720lt (0/+10 °C) - R290

The company reserves the right to make modifications to the products without prior notice. All information correct at time of printing.

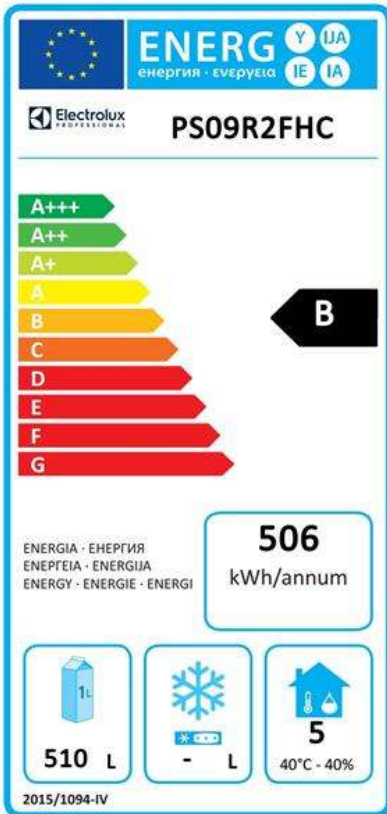

### EU energy labelling from 1st July 2016

The European energy labelling scheme for professional refrigerators and freezers is based on requirements setting Minimum Energy Performance standards for commercial refrigeration cabinets sold within the EU.

These requirements are designed to drive energy efficiency and environmentally friendly approach for professionals. The European energy labelling scheme will apply to all manufacturers and importers who sell and market products within the EU and it is mandatory across Europe. Important: all products which consume energy above the minimum level will not be able to be sold within the EU from 1 July 2016.

SI 2020 No. 1528.

Important: all products which consume energy above the minimum level will not be able to be sold within the EU from 1 July 2016.

